



# Installation Instructions

Application Fits  
2014-2015 Mazda 6  
X7301 & X7302

2" & 1.25" EcoHitch Stealth

200 lb. Tongue Weight/ 2,000 lb. Towing Weight

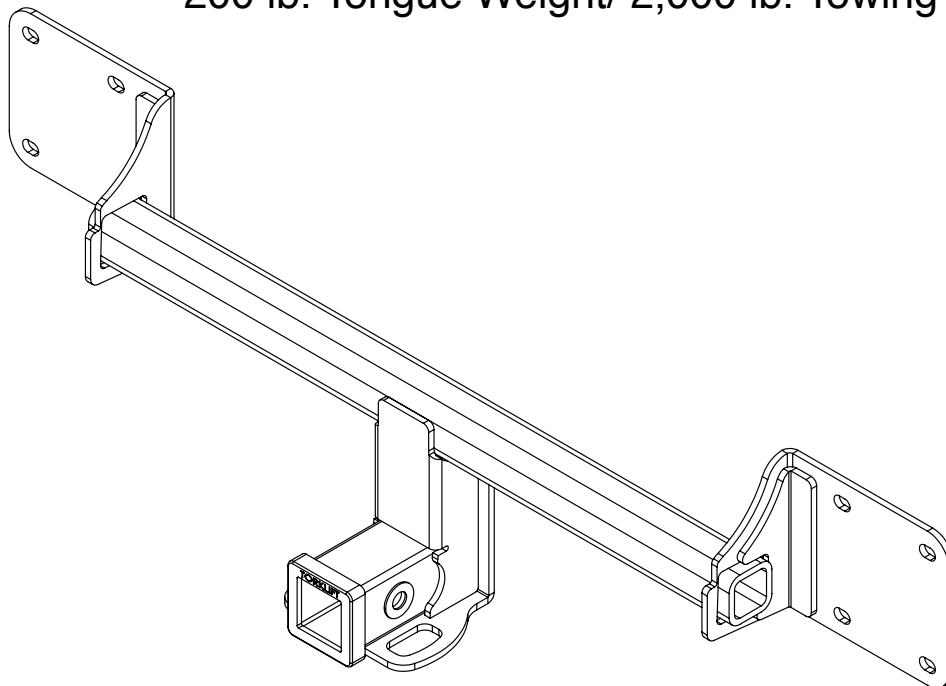

Torklift Central  
315 Central Ave N  
Kent, WA 98032  
253-854-1832  
[www.torkliftcentral.com](http://www.torkliftcentral.com)  
[support@tlcentral.com](mailto:support@tlcentral.com)

## Stay Connected



*Bolt Kit Weight: +/-*  
*QTY Fastener*

*Hardware Included*

1 18" Trim-Lok

**READ THESE INSTRUCTIONS THOROUGHLY AND ACCOUNT FOR ALL HARDWARE LISTED BEFORE BEGINNING INSTALLATION!**

**Step 1.** Raise vehicle on suitable jack stands or hoist.

**Step 2.** Remove (2) lag screws located in the driver and passenger side rear wheel wells. See Figure [1].

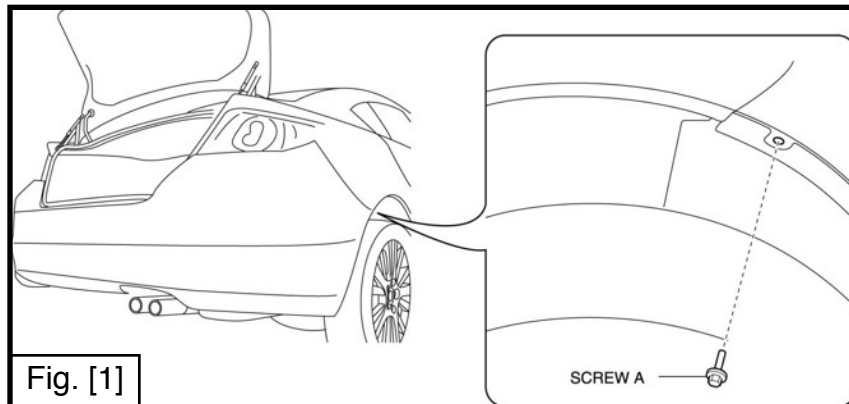

**Step 3.** Remove (2) lag screws and (2) push pin clips located along the underside of the bumper fascia. See Figure [2].

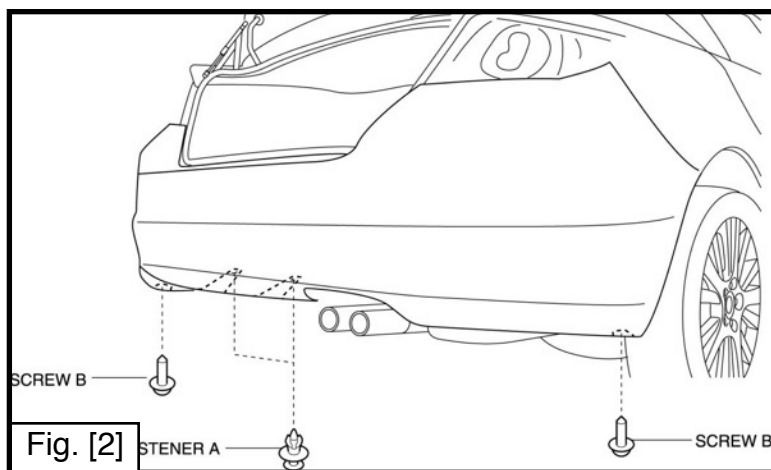

**Step 4.** Open the trunk lid and remove the carpet panel.

**Step 5.** Remove (4) button clips from the plastic panel in the trunk compartment and remove by pulling upwards. See Figure [3].

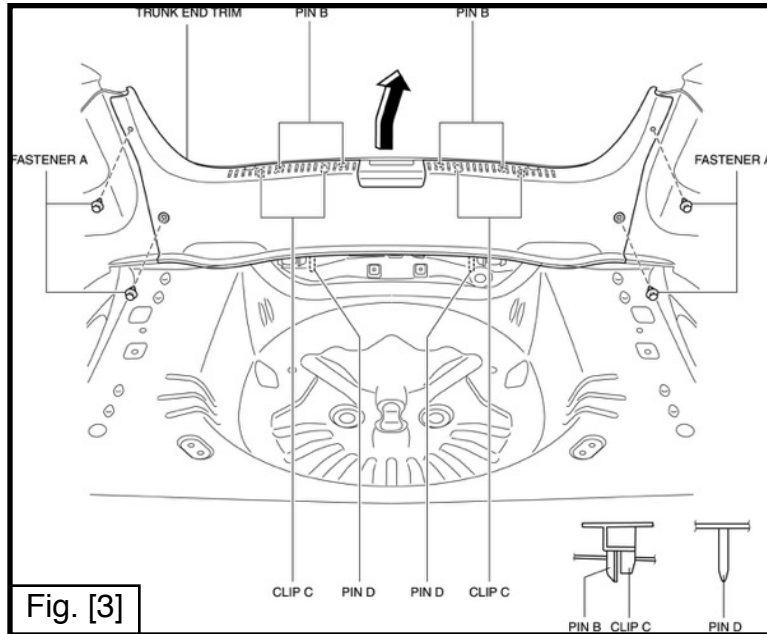

**Step 6.** Remove (4) push pin clips from the carpeted wall panels to access the tail light assemblies. Remove (3) nuts and the (3) wire harness connections from the tail light assemblies. Remove the tail light assemblies by sliding the assembly rearward. See Figure [4].

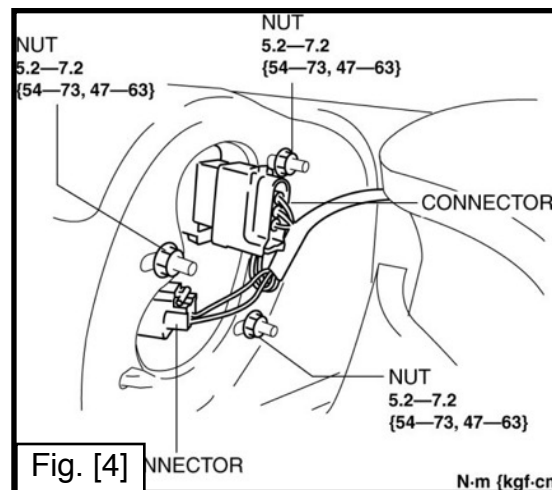

**Step 7.** Remove (1) lag screw located under the tail light assembly on the driver and passenger side. See Figure [5].



**Step 8.** Remove the plastic covers from the trunk lid edge and remove the (1) lag screw. See Figure [6].

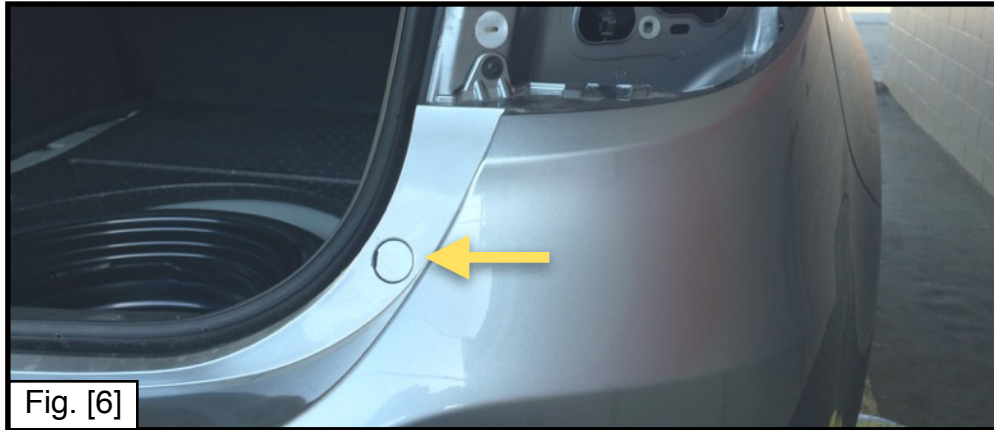

Fig. [6]

**Step 9.** Starting at the passenger side, gently peel the bumper fascia away from the vehicle working your way toward the rear. Continue working along toward the driver side until the bumper is completely removed. It may be helpful to have an assistant during this process to avoid damaging the bumper fascia. See Figure [7].



Fig. [7]

**Step 10.** Once the bumper is removed, lower the exhaust by using a lubricant such as WD-40 or equivalent to loosen the rubber exhaust bungs. See Figure [8].

**WARNING:** Do not let exhaust hang freely! Support exhaust with a stand, block of wood, wire, or other support. See Figure [8].

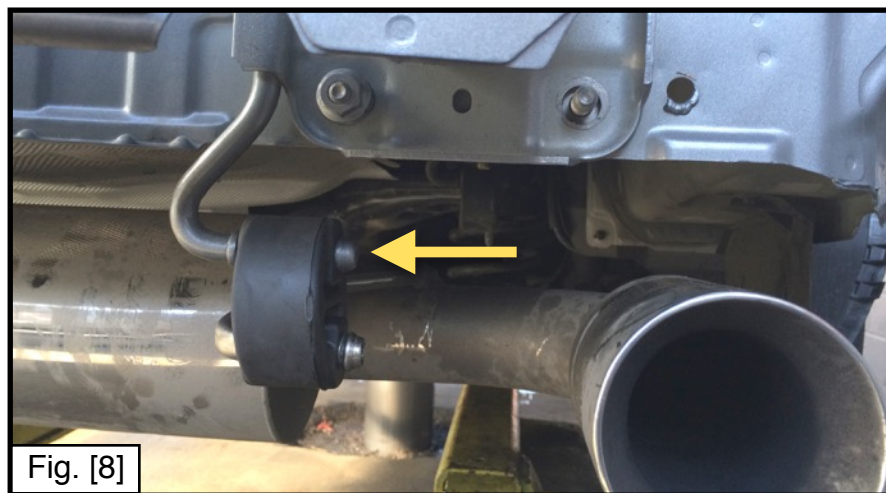
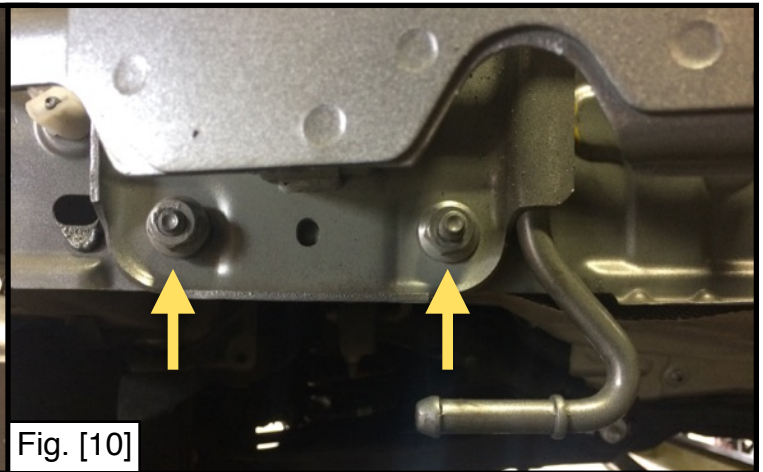
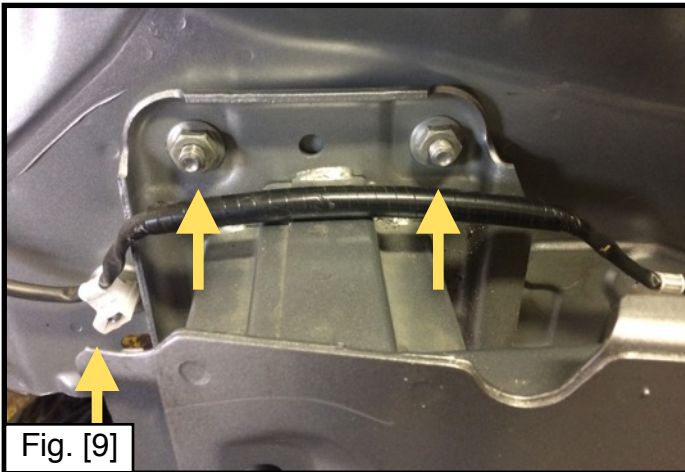

Fig. [8]

**Step 11.** Carefully remove wire harness and sensor if equipped and move out of way of the impact bar. Remove the impact bar by removing the (8) factory nuts. See Figure [9],[10],[11].



**Step 12.** Place the EcoHitch into position on the impact bar stud bolts then replace the impact bar over the EcoHitch on the stud bolts. Secure with the factory nuts and hand tighten at this time. Once the hitch and impact bar evenly secured, torque the factory nuts to 17ft-lbs.

**Step 13.** Mark and trim a 3-1/2" x 4-3/4" cut out at the center of the bumper for the receiver to drop through. Apply the Trim-Lok to the edge of the cut and trim any excess. See Figure [12].

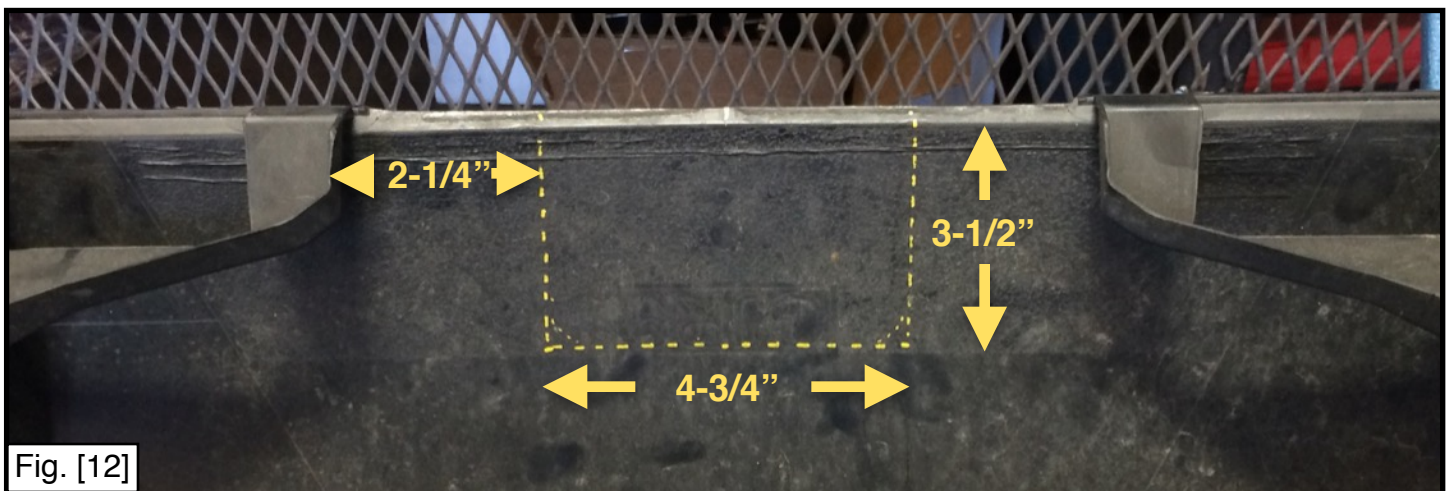

**Step 14.** Reinstall exhaust by re-lubricating the rubber exhaust bungs. Reinstall the wire harness and sensor then the bumper by following these steps in reverse starting at Step 10.

**Congratulations on the completed installation of the Mazda 6 Stealth EcoHitch!** It is designed with a lifetime warranty for a lifetime of enjoyment. If you have any questions or suggestions please contact our tech support at [support@tlcentral.com](mailto:support@tlcentral.com) or by phone at (253) 854-1832.



# WARRANTY/DISCLAIMER INFORMATION

Torklift Central requires proof of purchase for warranty claim registration, with pictures of any defective product before issuing a replacement. Torklift will not accept claims on any product without proof of purchase, which can be faxed, scanned, emailed or mailed to the information provided below. Torklift Central warrants its hitches, custom hitch receivers and accessories (excluding electrical wire harnesses which carry a warranty from their specified manufacturer) from date of purchase against defects in material and workmanship under normal use and service for the ownership life of the original consumer purchaser. Torklift Central will replace free of charge any part that proves defective in material or workmanship when presented to Torklift Central, transportation charges prepaid by purchaser, at the address below. **This warranty is limited to defective parts replacement only. Labor charges and/or damage incurred in installation or replacement, as well as incidental and consequential damages connected therewith are excluded.** This warranty does not include normal wear and tear or the finish and paint. Rusting, cracking or peeling of the finish is also excluded. Some states do not allow the exclusion or limitation of incidental or consequential damages, so the above limitation or exclusion may not apply to you. Any damage to Torklift Central products as a result of misuse, abuse, neglect, accident, improper installation or any use violative of instructions furnished by Torklift Central will void the warranty. This warranty gives you specific legal rights and you may also have rights, which vary from state to state. With warranty service, you may be able to go to a small claims court, a state court or a federal district court.

Although Torklift Central trailer hitches are both tested and rated for towing within the specific capacity label found on each trailer hitch. Torklift Central assumes no liability for vehicle manufacturers warranty due to the use of a Torklift Central trailer hitch being used for towing behind any vehicle or using the trailer hitch in a manner that it was not designed for. Although this specific trailer hitch has a load rating, which includes trailer tongue weight, and a trailer weight carrying capacity, Torklift Central is not responsible for the voiding of any warranty on any vehicle due to factory towing limitations. All vehicle warranties are the sole property and responsibility of the owner of the vehicle that the Torklift Central trailer hitch is installed upon. Torklift Central does not endorse towing behind any vehicle if the vehicles manufacturer states that towing is not recommended. Check your vehicle's owner's manual for the proper tow rating of your vehicle.

**ADDRESS:** 315 Central Ave N. Kent, WA 98032

**\*WARNING\*** Your vehicle may have a lower tow rating than this trailer hitch. If your vehicle's tow rating is less than the rated towing capacity on your Torklift Central trailer hitch, your trailer hitch capacity is limited to your vehicle's factory rated towing capacity.

**FOR EXAMPLE:** the label on your Torklift Central trailer hitch states it's capacity is rated for 500 pounds tongue weight and 5,000 pounds towing weight. However your vehicle's factory rated towing capacity is limited to only 350 pounds tongue weight and 3,500 pounds towing weight. In this example your maximum towing capacity of your Torklift Central trailer hitch is limited to 350 pounds tongue weight and 3,500 pounds towing weight as stated by your vehicle's maximum factory tow rating.

**\*DANGER\*** Never exceed your vehicle's manufacturer's recommended towing capacity which may be a lower rating than this trailer hitch

Unsure of your tow rating? Download our towing app from the app store to find your vehicles tow rating.  
[www.torkliftcentral.com/app.php](http://www.torkliftcentral.com/app.php)